

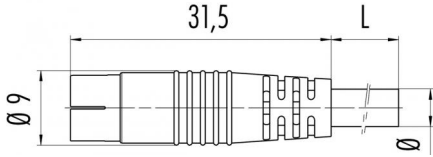

|                     |  |
|---------------------|--|
| Product description | <b>Snap-In IP40 cable connector, Contacts: 4, not shielded, moulded on cable, IP40, Standard cable, PVC black, 4 x 0.25 mm<sup>2</sup></b> |
| Area                | <b>Snap-In IP40 series 709</b>   |
| Order number        | <b>79 9003 12 04</b>   |

| Illustration  | Scale drawing  | Contact arrangement (Plug-in side)  |   |                     |   |                    |   |                   |   |                       |
|---|--|---|---|---------------------|---|--------------------|---|-------------------|---|-----------------------|
|  |  |  <table style="margin-left: auto; margin-right: 0;"> <tr> <td>1</td> <td>braun/<i>brown</i></td> </tr> <tr> <td>2</td> <td>weiß/<i>white</i></td> </tr> <tr> <td>3</td> <td>blau/<i>blue</i></td> </tr> <tr> <td>4</td> <td>schwarz/<i>black</i></td> </tr> </table> | 1 | braun/ <i>brown</i> | 2 | weiß/ <i>white</i> | 3 | blau/ <i>blue</i> | 4 | schwarz/ <i>black</i> |
| 1   | braun/ <i>brown</i>  |   |   |                     |   |                    |   |                   |   |                       |
| 2   | weiß/ <i>white</i>   |   |   |                     |   |                    |   |                   |   |                       |
| 3   | blau/ <i>blue</i>  |   |   |                     |   |                    |   |                   |   |                       |
| 4   | schwarz/ <i>black</i>  |   |   |                     |   |                    |   |                   |   |                       |

## Technical data

### General values

|                          |                      |
|--------------------------|----------------------|
| Connector design         | cable connector      |
| Connector locking system | snap                 |
| Termination              | moulded on cable     |
| Wire gauge (mm)          | 0.25 mm <sup>2</sup> |
| Wire gauge (AWG)         | 24                   |
| Upper limit temperature  | 70 °C                |
| Lower limit temperature  | - 20 °C              |
| Customs tariff number    | 85444290             |
| Packaging Unit           | 100                  |

### Electrical values

|                           |                      |
|---------------------------|----------------------|
| Rated current (40 °C)     | 3 A                  |
| Rated voltage             | 60 V                 |
| Rated impulse voltage     | 800 V                |
| Pollution degree          | 1                    |
| Overvoltage category      | II                   |
| Insulating material group | III                  |
| Insulation resistance     | ≥ 10 <sup>10</sup> Ω |
| EMC compliance            | not shielded         |
| Degree of protection      | IP40                 |
| Mechanical operation      | > 100 Mating cycles  |

### Cable data

|  |               |
|--|---------------|
| Cable length                             | 2 m           |
| Sheath material                          | PVC           |
| Single-lead insulation                   | PVC           |
| Halogen free                             | No            |
| Single-lead structure                    | 32x0.1 mm     |
| Cable diameter                           | 4.5 mm        |
| Cable color                              | black         |
| Conductor resistance                     | 80Ω/Km (20°C) |
| Temperature range, moving cable, °C from | -5°C          |
| Temperature range, moving cable, °C to   | +70°C         |
| Temperature range, fixed cable, °C from  | -25°C         |
| Temperature range, fixed cable, °C to    | +70°C         |
| Bending radius, fixed cable              | ≥ 5 x Ø       |
| Bending radius, moving cable             | ≥ 10 x Ø      |

### Material

|                       |                      |
|-----------------------|----------------------|
| Contact material      | CuZn (brass)         |
| Contact plating       | Au (gold)            |
| Contact body material | PA                   |
| Housing material      | PUR                  |
| REACH SVHC            | CAS 7439-92-1 (Lead) |

|                     |  |
|---------------------|--|
| Product description | <b>Snap-In IP40 cable connector, Contacts: 4, not shielded, moulded on cable, IP40, Standard cable, PVC black, 4 x 0.25 mm<sup>2</sup></b> |
| Area                | <b>Snap-In IP40 series 709</b>   |
| Order number        | <b>79 9003 12 04</b>   |

## Security notices

The connectors are designed for use in plant, control system and electrical equipment. The end user is responsible for checking whether the connectors are suitable for use in other applications.